

PARÇA KODU PART CODE	PARÇA ADI PART NAME	s ÖLÇÜSÜ (KALINLIK) s MEASURE (THICKNESS)	Malzeme Material	Kaplama / Coating		
				SN	AG	Nİ
TŞ 2413 DP	ŞASE TERMİNAL Ø4.2 =DP=	-----	(CuZn30) Pirinç / Brass	-	-	-
TŞ 2413 RP	ŞASE TERMİNAL Ø4.2 =RP=	-----	(CuZn30) Pirinç / Brass	-	-	-
TŞ 2413 RPK	ŞASE TERMİNAL Ø4.2 =RPK=	-----	(CuZn30) Pirinç / Brass	+	-	-

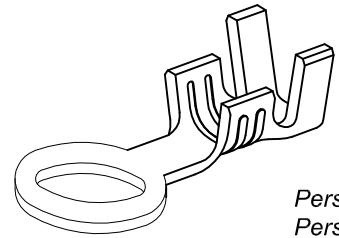
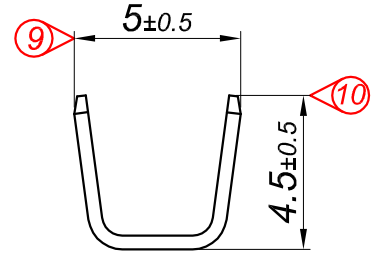
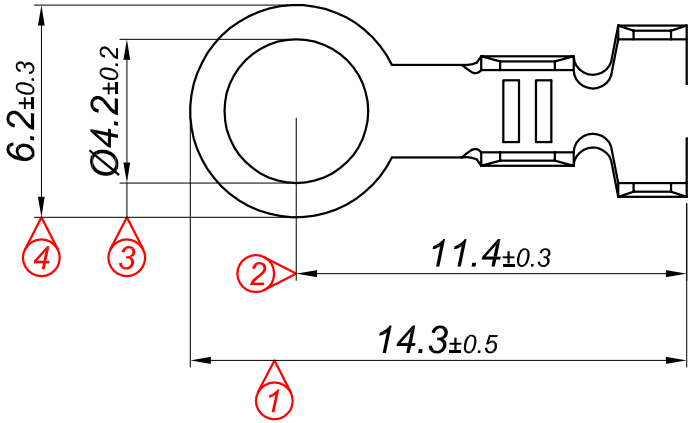
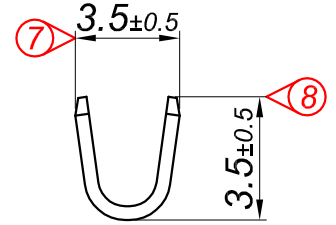
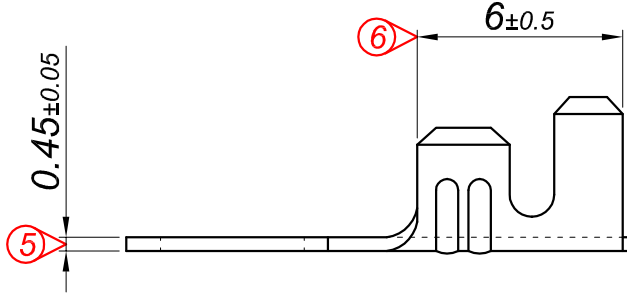

Perspektif
Perspective

Kalıp çıkış yönü
Mold output direction

Makara açılım yönü
Reel opening direction

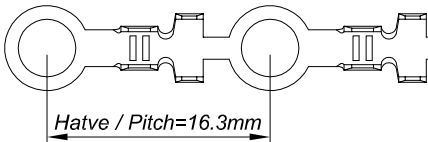

Ölçek
Scale : 2 / 1

Kablo Kesiti

Wire Section : 0.50 - 1.50 mm²

Resim üzerinden ölçü almayınız
do not measure on drawing

Tarih / Date	19.07.2013	İmza /Signature	Ölçek /Scale			
Çizen / Desing	M.Yağcı					
Onay / Approval	S.Gölcük		5 / 1	No	Değişiklik / Revision	Tarih/Date



Parça Adı:
Part Name

ŞASE TERMİNAL Ø4.2

Parça Kodu:
Part Code

TŞ 2413